

307-33/40-ASMD

High-frequency spindle
Manual tool change
With Dittel Acoustic Emission Sensor

Dressing spindle for trueing
grinding wheels



Technical specifications

- High precision steel ball bearings – 2 Pcs.
- Lifetime lubricated, maintenance free
- Motor type: Asynchron / 3Phase
- Nominal output power: 80W / max. 100 W
- Voltage: max. 30 V
- Current: 4A / max. 6A
- Frequency: max. 667 Hz
- Rotation speed: max. 40.000 rpm
- Speed monitoring: transmitter (6Imp/min)
- Temperatur monitoring: PTC
- Sealing-air
- Housing diameter: 33 mm / □40mm
- Tool change: manual tool change
- Clamping range: \varnothing 6mm
- Spindle cable 0,7m with 7-pole plug
- Spindle cable extension 10m
- AE-System sensor cable 0,7m with 2-pole
- Weight: 0,6 Kg

Dimensions

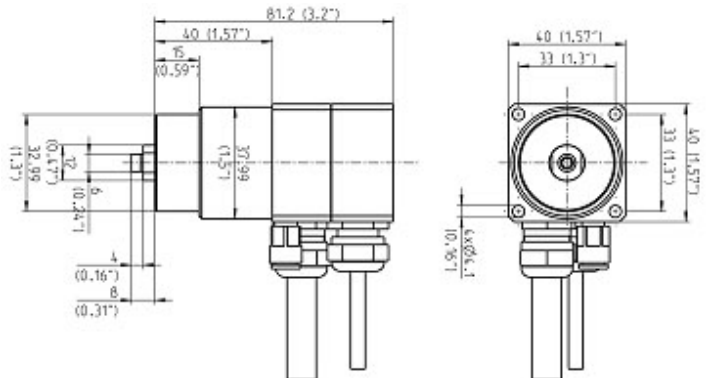

Power-, torque- and speed diagram

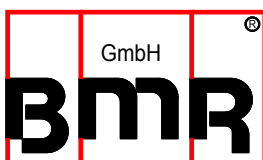
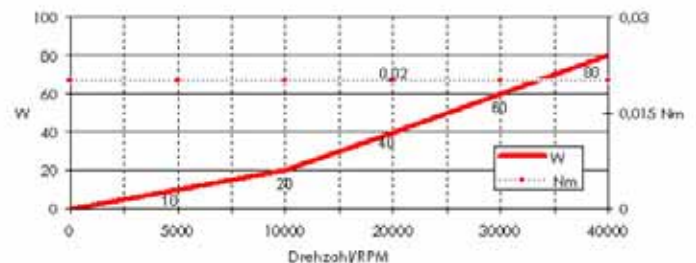

BMR GmbH • elektrischer & elektronischer Gerätebau
Unterreichenbacher Straße 1 • D-90455 Nürnberg-Katzwang
Tel. +49 (0)9122-631480 • Fax +49 (0)9122-6314829
info@bmr-gmbh.de www.bmr-gmbh.de